

GP Batteries

Data Sheet

Model No.: GP55AFK

Type	Rechargeable Nickel Cadmium Cylindrical Cell	
Nominal Dimension (with Sleeve)	Φ = 17.0mm H = 28.5mm	
Applications	Recommended discharge current 55 to 1650mA	
Nominal Voltage	1.2V	
Nominal Capacity	Minimum : 550mAh Typical : 605mAh when discharge at 110mA to 1.0V at 20°C	
Charging Condition	55mA for 16 hrs at 20°C	
Fast Charge	275mA to 550mA (0.5 to 1C) with charge termination control Recommended control parameters: -ΔV : 10 - 20mV Timer : 120% nominal input	
Service Life	>500 cycles (IEC 61951-1)	
Continuous Overcharge	55mA maximum current for 1 year No conspicuous deformation and/or leakage	
Weight	13.9g	
Internal Resistance	Average 40mΩ upon fully charged (Range 30-60mΩ) at 1000Hz	
Max. Charging Voltage	1.5V at 55mA charging	
Ambient Temperature Range	Standard Charging	0 to 45°C
	Fast Charging	10 to 45°C
	Discharging	-20 to 50°C
	Storage	-20 to 35°C
	Storage (1 week)	-20 to 60°C

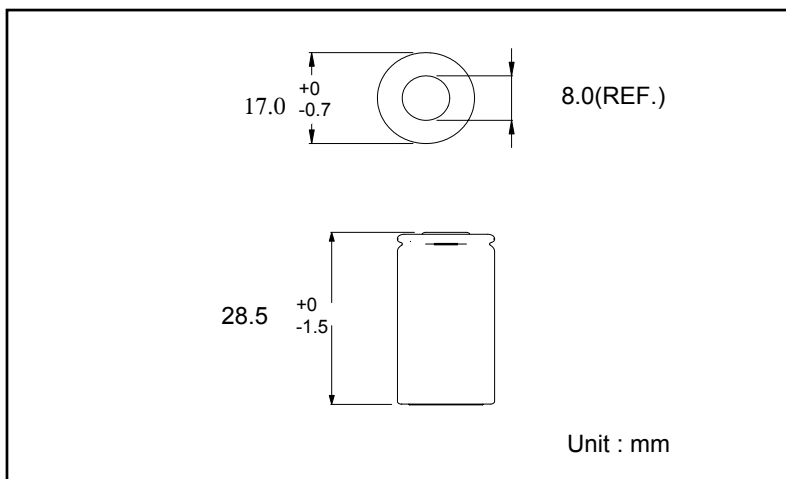

Fast Charge (Charge control required)

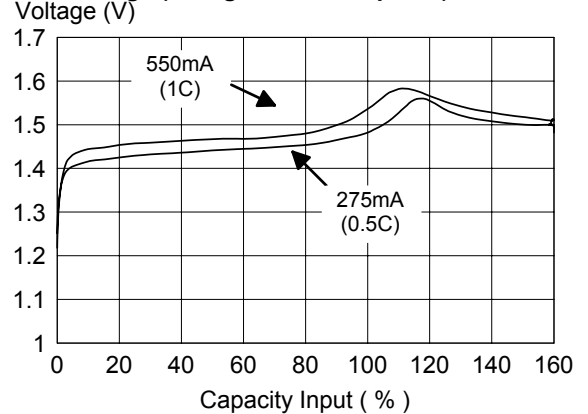

Low Rate Discharge

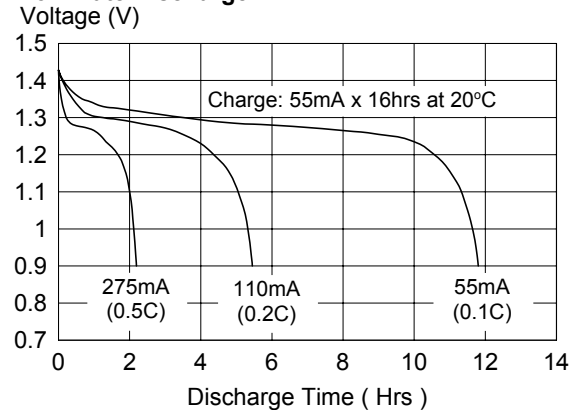

High Rate Discharge

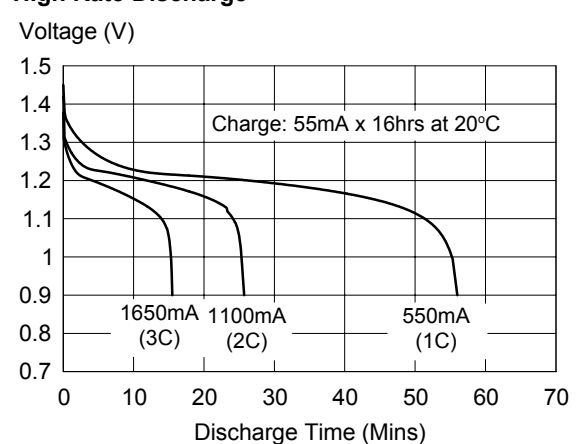

* The information (subject to change without prior notice) contained in this document is for reference only and should not be used as a basis for product guarantee or warranty. For applications other than those described here, please consult your nearest GP Sales and Marketing Office or Distributors.